

The amcot Silver Series Cooling Tower

Design Features:

Lightweight and compact, the AMCOT cooling tower provides quick and easy installation. Job site assembly is simplified by the modular design of all components.

Prevailing wind directions will not affect cooling tower performance due to the unique circular design of the basin and casing.

Casing:

Easy access through casing simplifies cleaning. Individual fiberglass panels are stainless steel bolted together for periodic wash down and general clean up.

The AMCOT FRP cooling tower is designed for durability and long life even under the most severe environmental weather conditions.

Fan Blades:

Aerodynamically designed propeller type fan blades are used to conserve power and assure quiet operation. AMCOT model ST-3 through ST-50 feature a factory balanced ABS plastic blade. AMCOT model ST-60 and above feature an all aluminum alloy adjustable fan.

Fan Motor:

AMCOT ST-3 through ST-200 have a direct drive motor. AMCOT ST-225 and larger feature a unique belt drive design to reduce noise levels to a minimum.

Water Distribution System:

AMCOT ST-3 through ST-60 use an ABS plastic sprinkler with stainless steel shaft. AMCOT ST-70 and above use an aluminum alloy sprinkler head. Both types of sprinkler heads require little or no head pressure loss and minimum maintenance.

Inlet Louvers:

Non rusting PVC plastic mesh provides easy access to sump while preventing foreign objects from entering water basin.

Ladder:

Provided for maintenance and inspection accessibility to fan and sprinkler systems. (Models ST-40 and above)

Fill Material:

Honeycomb heat embossed PVC is formed to permit high heat transfer efficiency. The AMCOT fill is suitable for operation with inlet water temperature up to 115°F. For temperature above this please select ST-P(polypropylene) or ST-W(wood) models.

Engineered for Cost Efficiency & High Performance

The fan motor is weather-proofed and totally enclosed allowing for less noise and more efficient long-term performance.

The sprinkler pipes are sturdy PVC material pierced with closely-spaced holes allowing thorough distribution of water in a rotating spray covering the entire surface of the filler.

The round design permits maximum air intake regardless of wind direction.

Efficient operation results from the smooth pumping of recirculated water through the stand pipe and up into the sprinkler pipes.

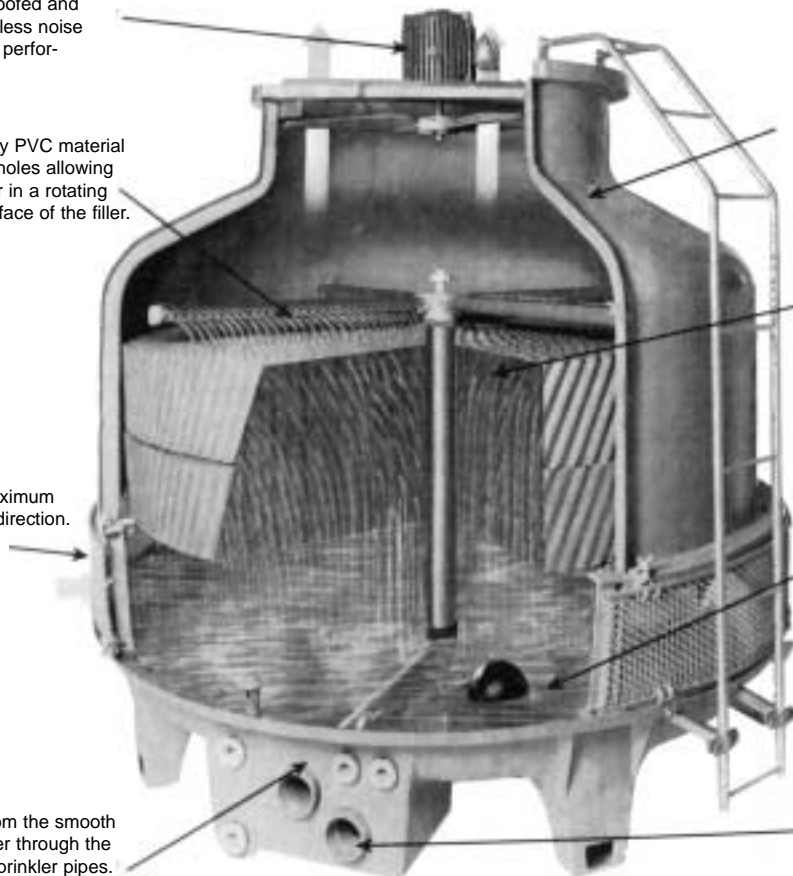

Housing panels and water basin are built of fiberglass reinforced plastic ensuring rust-free long term performance even under the most severe environmental conditions.

The efficiently designed PVC filler creates a surface area that allows for maximum dispersion of water which creates a superior cooling effect.

A large-capacity, durable water basin constructed from rust-proof fiberglass reinforced plastic guarantees low maintenance and long-term operation.

A large diameter outlet pipe draws a constant supply of cooled water from the basin to serve the facility.

Dimensions and Pipe Connections

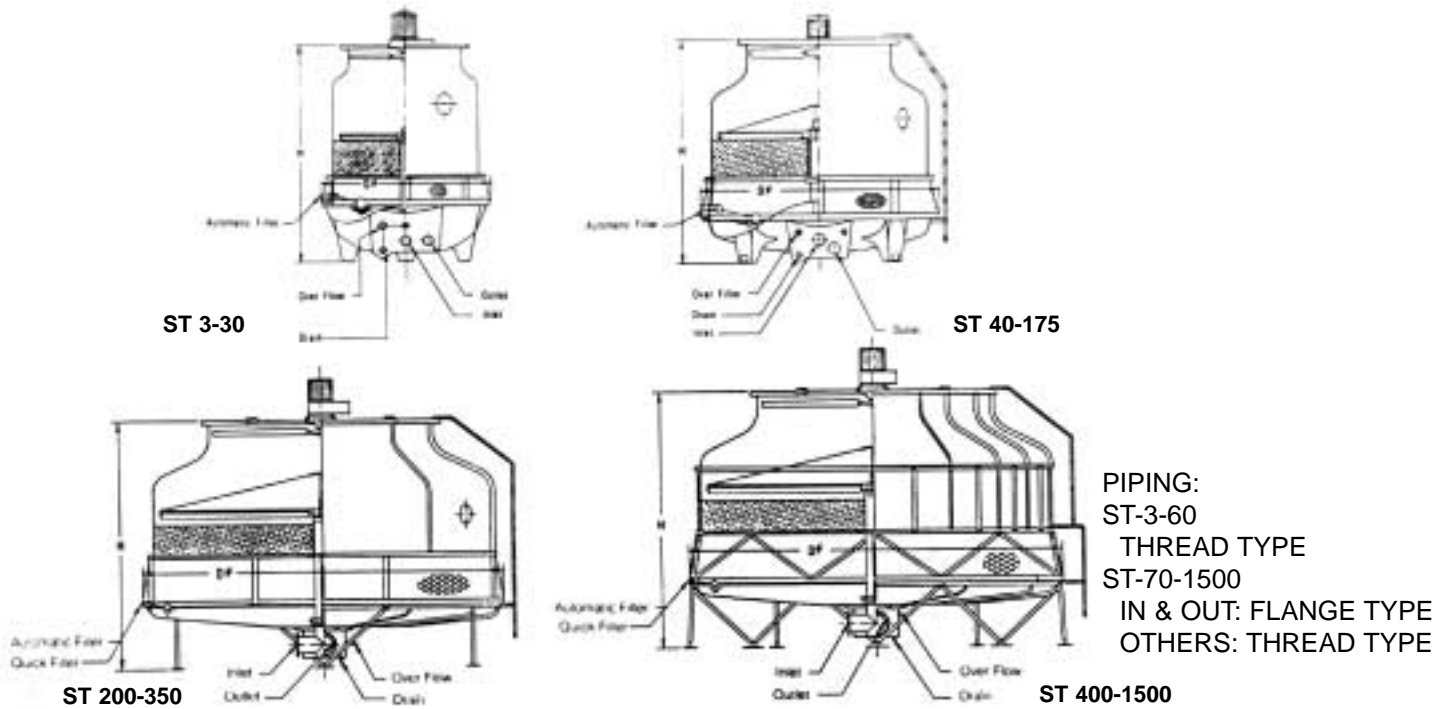

AMCOT COOLING TOWER												
ST MODEL	DIMENSIONS (INCH)		PIPE CONNECTIONS (INCH)						FAN MOTOR (HP)	FAN DIAMETER (INCH)	AIR VOLUME (CFM)	NOMINAL WATER FLOW (GPM)
	HEIGHT	DIA.	IN	OUT	O	Dr	FLO	Q				
3	50	27	1½	1½	1	¾	½		½	19½	870	6
5	52	34	1½	1½	1	¾	½		½	19½	2,100	10
8	56	34	1½	1½	1	¾	½		½	19½	2,620	16
10	54	42	1½	1½	1	¾	½		¾	26½	3,500	20
15	59	46	2	2	1	1	½		¾	26½	4,700	30
20	63	54	2	2	1	1	½		1	30	6,300	40
25	71	54	2½	2½	1	1	½		¾	30	7,000	50
30	68	62	2½	2½	1	1	½		1	30	8,100	61
40	75	72	2½	2½	1	1	¾		1½	38	9,800	83
50	75	79	3	3	1	1	¾		1½	38	11,500	105
60	75	79	3	3	1	1	¾		1½	46	14,700	125
70	80	86	4	4	1	1	¾		1½	46	17,500	145
80	80	86	4	4	1	1	¾		2	46	18,900	168
100	85	105	4	4	1	1	1		3	58	24,500	208
125	87	120	5	5	2	1	1		3	58	29,060	262
150	90	130	5	5	2	2	1		5	69	33,260	318
175	98	130	5	5	2	2	1		5	69	40,250	369
200	118	149	6	6	2	2	1¼	1¼	5	69	43,760	426
225	126	149	6	6	2	2	1¼	1¼	7½	93	61,270	460
250	126	149	8	8	2	2	1¼	1¼	7½	93	61,270	520
300	132	175	8	8	2	2	1¼	1¼	10	93	77,020	620
350	134	189	8	8	2	2	1¼	1¼	10	93	77,020	744
400	153	204	8	8	4	2	2	2	15	117	91,030	845
500	155	220	10	10	4	2	2	2	15	117	91,030	1113
600	171	260	10	10	4	2	2	2	20	133	125,000	1278
700	181	260	10	10	4	2	2	2	20	133	125,000	1546
800	194	299	12	12	4	3	2	2	30	141	175,000	1703
1000	203	299	12	12	4	3	2	2	30	141	175,000	2253
1250	231	332	12	12	4	3	2½	2½	40	168	218,900	2824
1500	240	332	14	14	4	3	2½	2½	50	168	264,800	3380

NOMINAL WATER FLOW IS DEFINED AS RATE OF WATER COOLED FROM 95°F TO 85°F WITH 78°F WET BULB TEMPERATURE

Recommended Concrete Base of Tower Support Stand

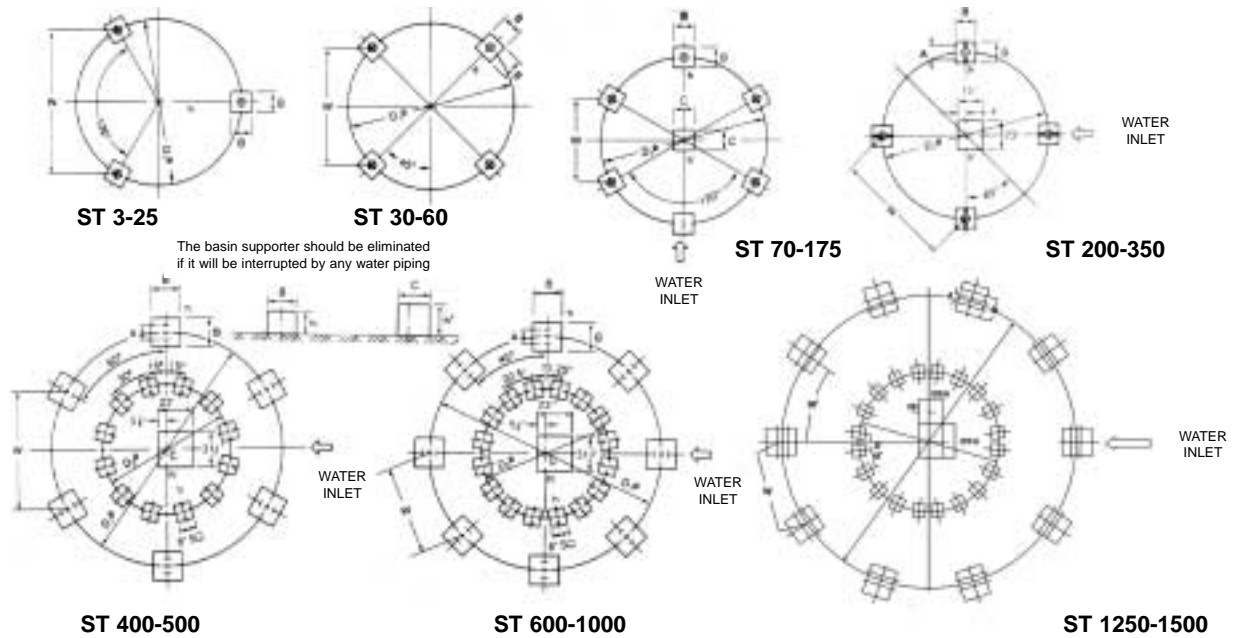

TOWER SUPPORT CONCRETE BASE														
WEIGHT (LB.)		DIMENSIONS (INCH)								ANCHOR BOLT			PUMP HEAD (FT.)	ST MODEL
										SIZE (INCH)	LENGTH (INCH)	QTY. (PCS.)		
DRY	OPERATING	D1	W	B	A	h	h'	C	D2					
62	161	18	15	8		6				½	4¾	3	5.0	3
86	251	21	18¾	8		6				½	4¾	3	5.0	5
93	262	21	18¾	8		6				½	4¾	3	5.0	8
123	443	29½	25	8		6				½	4¾	3	5.0	10
139	536	34	30	8		6				½	4¾	3	5.3	15
190	719	44	38¾	8		6				½	4¾	3	5.6	20
227	887	44	38¾	8		6				½	4¾	3	5.6	25
253	1,074	52½	37	8		6				½	4¾	4	6.0	30
369	1,133	57	40	10		8				½	4¾	4	6.6	40
435	1,313	66	46¾	10		8				½	4¾	4	6.6	50
504	1,472	66	46¾	10		8				½	4¾	4	6.6	60
610	1,555	69	34½	10		8	12	10		½	4¾	5	6.6	70
642	1,588	69	34½	10		8	12	10		½	4¾	5	6.6	80
887	2,361	92½	46¾	12		12	14	12			8	5	8.2	100
1,025	2,983	103	51½	12		12	14	12			8	5	10.0	125
1,375	5,731	112½	56¾	12		12	13½	16			8	5	10.0	150
1,569	5,887	112½	56¾	12		12	13½	16			8	5	11.0	175
1,914	7,612	132	93	12	5	12	16	23			8	8	11.0	200
2,112	7,744	132	93	12	5	12	16	23			8	8	11.0	225
2,266	7,854	132	93	12	5	12	16	23			8	8	12.0	250
2,823	9,995	156	110	12	5½	12	16	23			8	8	12.0	300
2,996	10,164	169	119	12	5½	12	16	23			8	8	13.2	350
4,776	14,984	200¾	100	20	5½	12	16	31½	114½	¾	8	12	13.2	400
5,342	15,550	216½	108¾	20	5½	12	16	31½	122	¾	8	12	13.2	500
7,401	23,637	255	97	20	5½	12	16	31½	141¾	¾	8	16	16.4	600
7,848	24,127	255	97	20	5½	12	16	31½	141¾	¾	8	16	18.2	700
9,636	26,356	295¾	113	20	5½	12	16	31½	163½	¾	8	16	20.0	800
10,199	27,359	295¾	113	20	5½	12	16	31½	163½	¾	8	16	20.0	1,000
14,419	57,341	328	101	20	5½	12	16	31½	168	¾	8	20	21.3	1,250
15,400	58,326	328	101	20	5½	12	16	31½	168	¾	8	20	23.0	1,500

NOTE: TONS OF REFRIGERATION AT 12,000 BTU/HR WITH 3 GPM/TON.